



Submersible Sewage Pump

Type DL

OPTIONS AVAILABLE

- Free standing type
- Q.D.C. type
- Dry-pit type

APPLICATIONS

- Sewage
- Waste Water
- Storm water drainage

FEATURES

- Air filled, Class F insulated, heavy duty motor, dissipates heat easily, operates cooler with higher efficiencies; longer service life with lower operating costs.
- Built-in motor protection with autocut, protects motor against overheating, single phasing, and no load; saves money on costly motor replacement.
- Molded cable prevents capillary action; reduces maintenance costs.
- Heavy duty ensures long, dependable operation and lowers maintenance costs.
- Large solids handling capabilities prevents clogging.
- Semi-open impellers offer the best design for handling stringy and/or abrasive materials due to the large wear area and open passageways, providing durability and longer life.
- High quality stainless steel shaft; provides high tensile strength, corrosion resistance, longer life, and lower maintenance costs.
- Double mechanical seals - silicon carbide lower seals, carbon/ceramic upper - hard faced upper and lower seals operate in an oil bath; providing longer service life and lower maintenance costs.
- Available for Q.D.C connection absorption, provides ease of maintenance for small sump type installations.



SECTIONAL VIEW

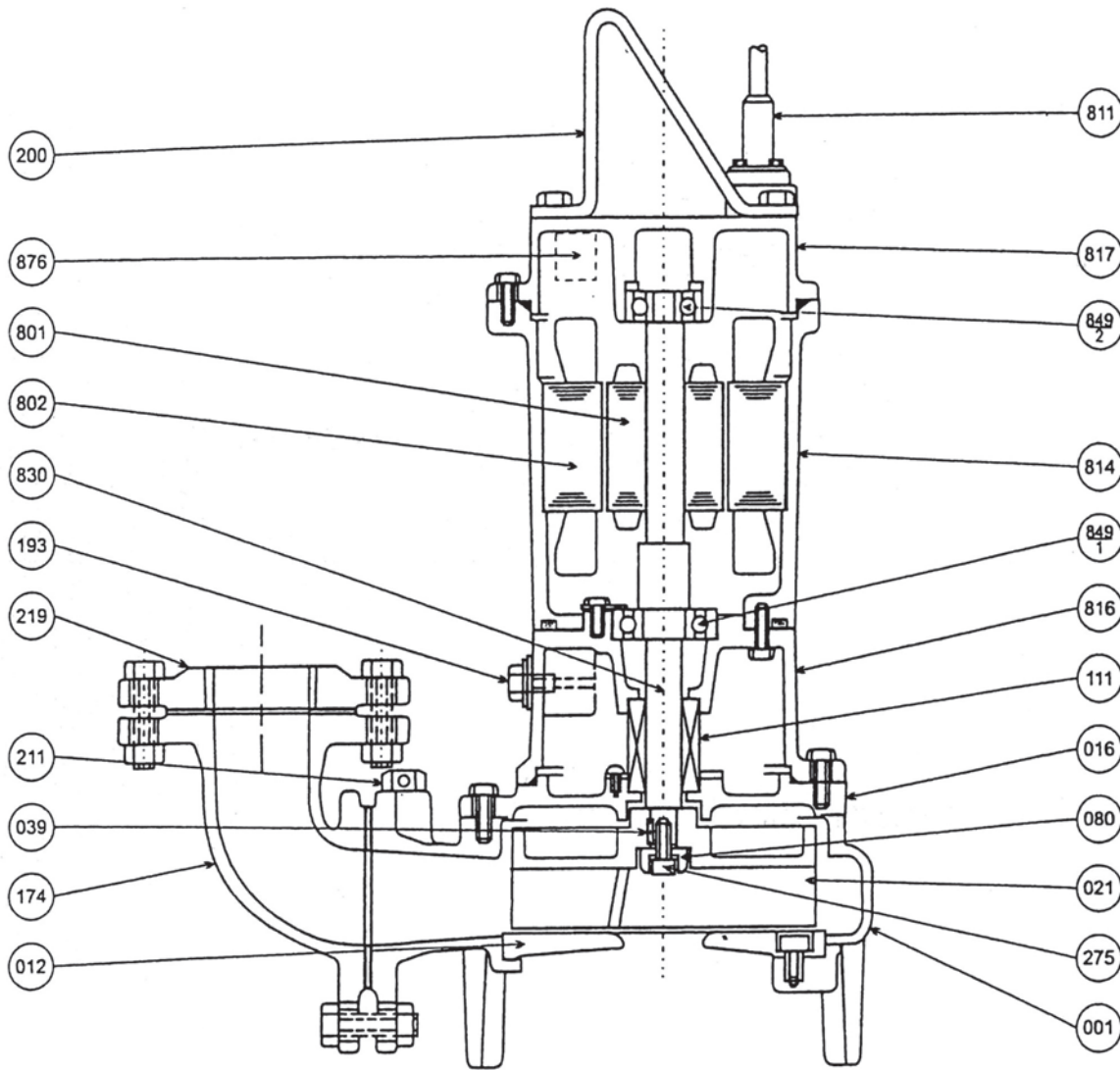

Item Number	Description	Material	Quantity per unit
001	Casing	FC200 Cast iron	1
012	Suction Cover	FC200 Cast Iron	1
016	Mechanical Seal Cover	FC200 Cast Iron	1
021	Impeller	Cast Iron	1
039	Impeller Key	SUS Stainless Steel	1
080	Bushing	SS Steel	1
111	Mechanical Seal	Upper : Carbon / Ceramic Lower : Silicon Carbide	1
174	Discharge Elbow	FC200 Cast iron	1
193	Oil Plug	C3604 or SUS304 Brass or Stainless Steel	1
200	Lifting Hanger	SS Steel	1
211	Airvent Valve	C3604 Brass	1
219	Companion Flange	FC200 Cast iron	1

Item Number	Description	Material	Quantity per unit
275	Impeller Bolt	SUS304 Stainless Steel	1
801	Rotor	Silicon Steel Sheet	1
802	Stator	Silicon Steel Sheet	1
811	Cable	Submersible type	1
814	Motor Frame	FC150 Cast Iron	1
816	Lower Bracket	FC150 Cast Iron	1
817	Upper Bracket	FC150 Cast iron	1
830	Shaft #	SUS403 Stainless Steel	1
849-1	Ball Bearing		1
849-2	Ball Bearing		1
876	Auto Cut		1

refers to pump side of shaft material

* This sectional view shows typical construction.

DIMENSION

Manual Models - DL (Wet Pit Model)

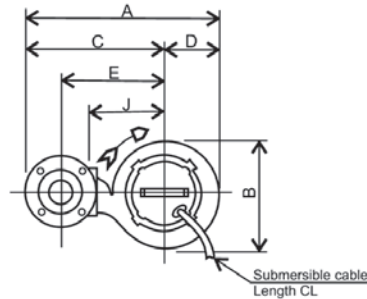
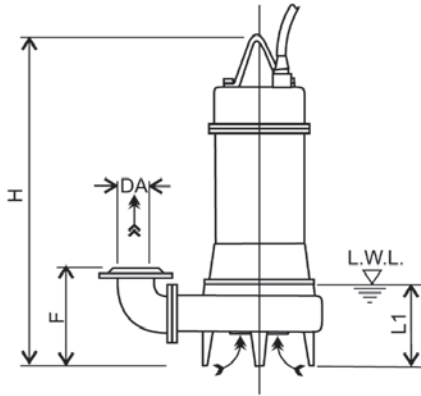

- Note:
- L.W.L. (Low Water Level) is limited to 10 minutes operation at low water level.
 - Is limited to 30 minutes operation with water level below top of motor.

Discharge Flange Dimensions (JIS 10kgf/cm²)

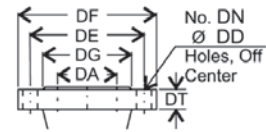

DA	DE	DF	DG	DT	DN	DD
65	140	175	116	18	4	15
80	150	185	126	18	4	15
100	175	210	151	20	8	15
150	240	280	212	22	8	19
200	290	330	262	26	12	23
250	355	400	324	30	12	25
300	400	445	368	32	16	25

Size DA	Model	Output kW	A	B	C	D	E	F	H	J	L1	CL (m)	Weight kg	
65	65 DL 51.5	1.5	497	291	353	144	265	200	576	200	140	10	52	
	65 DLD 55.5A	5.5	573	339	403	170	315	215	765	250	260	10	117	
	65 DLD 57.5A	7.5	640	414	433	207	345	215	765	280	260	10	140	
	65 DL 511A	11	640	414	433	207	345	215	864	280	260	10	167	
	65 DL 515A	15	696	486	453	243	365	215	948	300	280	10	210	
	65 DL 518A	18.5	696	486	453	243	365	215	951	300	280	10	231	
	65 DL 522A	22	696	486	453	243	365	215	951	300	280	10	240	
80	80 DL 51.5	1.5	524	292	378	146	285	220	597	210	165	10	55	
	80 DL 52.2	2.2	542	308	388	154	295	220	654	220	165	10	67	
	80 DL 53.7	3.7	567	328	403	164	310	220	687	235	165	10	75	
	80 DLD 55.5A	5.5	588	339	418	170	325	220	765	250	260	10	119	
	80 DLC 55.5	5.5	618	379	428	190	335	307	753	260	205	10	134	
	80 DLD 57.5A	7.5	655	414	448	207	355	220	765	280	260	10	142	
	80 DLC 57.5	7.5	648	399	448	200	355	305	751	280	205	10	148	
	80 DL 511A	11	655	414	448	207	355	220	864	280	260	10	169	
	80 DL 515A	15	711	486	468	243	375	220	948	300	280	10	212	
	80 DL 518A	18.5	711	486	468	243	375	220	951	300	280	10	233	
80 DL 522A	22	711	486	468	243	375	220	951	300	280	10	242		
100	100 DL 53.7	3.7	614	335	445	169	340	250	706	235	185	10	79	
	100 DLB 55.5	5.5	646	369	460	186	355	323	768	250	205	10	123	
	100 DLC 55.5	5.5	660	379	470	190	365	322	753	260	205	10	134	
	100 DLB 57.5	7.5	673	385	480	193	375	323	760	270	205	10	141	
	100 DLC 57.5	7.5	690	399	490	200	385	320	751	280	205	10	148	
	100 DL 511	11	701	402	500	201	395	323	859	290	205	10	180	
	100 DL 515	15	741	441	520	221	415	330	954	310	205	10	230	
	100 DL 518	18.5	741	441	520	221	415	330	958	310	205	10	285	
	150 DL 55.5	5.5	750	398	550	200	410	381	799	280	245	10	146	
	150 DL 57.5	7.5	780	418	570	210	430	377	784	300	245	10	158	
150	150 DL 511	11	810	438	590	220	450	377	883	320	245	10	199	
	150 DL 515	15	810	438	590	220	450	377	972	320	245	10	237	
	150 DL 518	18.5	848	476	610	238	470	381	979	340	245	10	300	
	150 DL 522	22	848	476	610	238	470	381	979	340	245	10	325	
	150 DL 530	30	912	520	650	262	510	468	1284	360	1080	10	355	
	150 DL 537	37	912	520	650	262	510	468	1434	360	1165	10	418	
	150 DL 545	45	912	520	650	262	510	468	1434	360	1165	10	456	
	200 DL 55.5	5.5	832	430	615	217	450	414	826	300	285	10	160	
	200 DL 57.5	7.5	863	453	635	228	470	410	809	320	285	10	176	
	200	200 DL 511	11	863	453	635	228	470	410	908	320	285	10	212
200 DL 515		15	896	479	655	241	490	411	995	340	285	10	260	
200 DL 518		18.5	932	512	675	257	510	415	1001	360	285	10	305	
200 DL 522		22	932	512	675	257	510	415	1001	360	285	10	330	
200 DL 530		30	937	520	675	262	510	483	1284	360	1080	10	355	
200 DL 537		37	937	520	675	262	510	483	1434	360	1165	10	418	
200 DL 545		45	937	520	675	262	510	483	1434	360	1165	10	456	
250 DL 57.5		7.5	969	525	700	269	500	622	904	370	400	10	260	
250 DL 511		11	993	541	720	273	520	634	1000	390	400	10	320	
250		250 DL 515	15	1007	549	730	277	530	646	1086	400	400	10	380
	250 DL 518	18.5	1007	549	730	277	530	646	1089	400	400	10	420	
	250 DL 522	22	1007	549	730	277	530	646	1089	400	400	10	440	
	250 DL 530	30	1125	660	790	335	590	706	1336	460	1132	10	458	
	250 DL 537	37	1125	660	790	335	590	706	1505	460	1236	10	522	
	250 DL 545	45	1125	660	790	335	590	706	1505	460	1236	10	540	
	300	300 DL 511	11	1100	588	798	302	575	671	1050	420	450	10	365
		300 DL 515	15	1100	588	798	302	575	671	1131	420	450	10	395
300 DL 518		18.5	1135	618	818	317	595	668	1131	440	450	10	440	
300 DL 522		22	1135	618	818	317	595	668	1131	440	450	10	465	
300 DL 530		30	1172	660	838	335	615	726	1336	460	1132	10	458	
300 DL 537		37	1172	660	838	335	615	726	1505	460	1236	10	522	
300 DL 545		45	1172	660	838	335	615	726	1505	460	1236	10	540	

DIMENSION WITH QDC

Applicable Models - 65DL, 80DL (1.5 ÷ 3.7 kW)

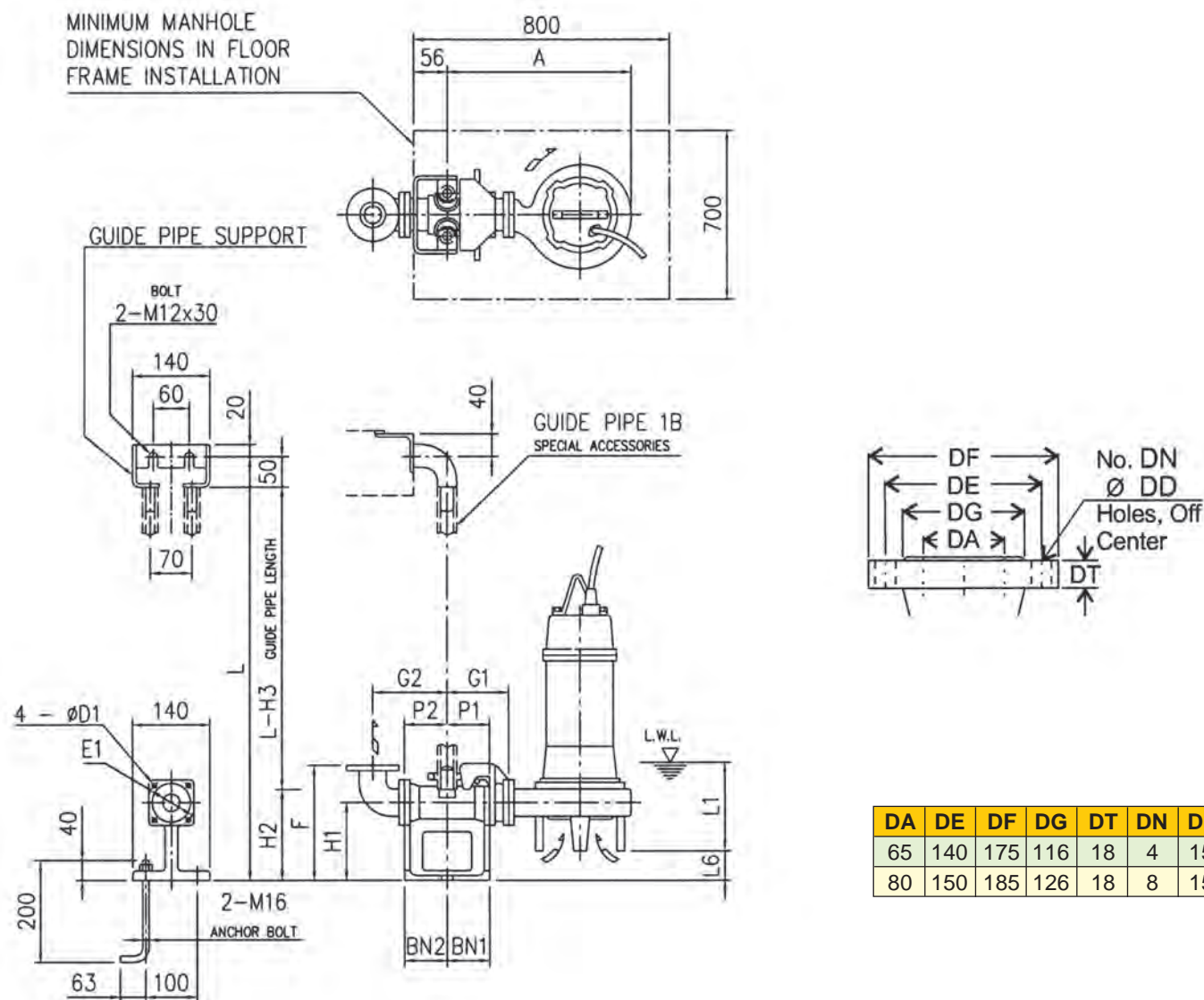

Size DA	Model	Output [kW]	A	P1	P2	G1	G2	F	H1	H2	H3	L1 (*)	L6	BN1	BN2	D1	E1	QDC Model	QDC Weight [kg]
65	65 DL 51.5	1.5	464	75	95	120	160	250	145	190	240	140	50	75	95	12	140	LM65	14
80	80 DL 51.5	1.5	481	75	90	125	165	285	175	230	280	165	65	75	90	15	155	LM80	17
	80 DL 52.2	2.2	499	75	90	125	165	285	175	230	280	165	65	75	90	15	155	LM80	17
	80 DL 53.7	3.7	524	75	90	125	165	285	175	230	280	165	65	75	90	15	155	LM80	17

(*) - L.W.L (Low Water Level)
 - Operation is limited to 10 minutes operation at L.W.L.
 - Operation is limited to 30 minutes operation with water level below top of motor.

Units: mm unless otherwise specified

DIMENSIONS WITH QDC

Applicable Models - 65DL, 80DL (5.5 ÷ 22kW), 100DL

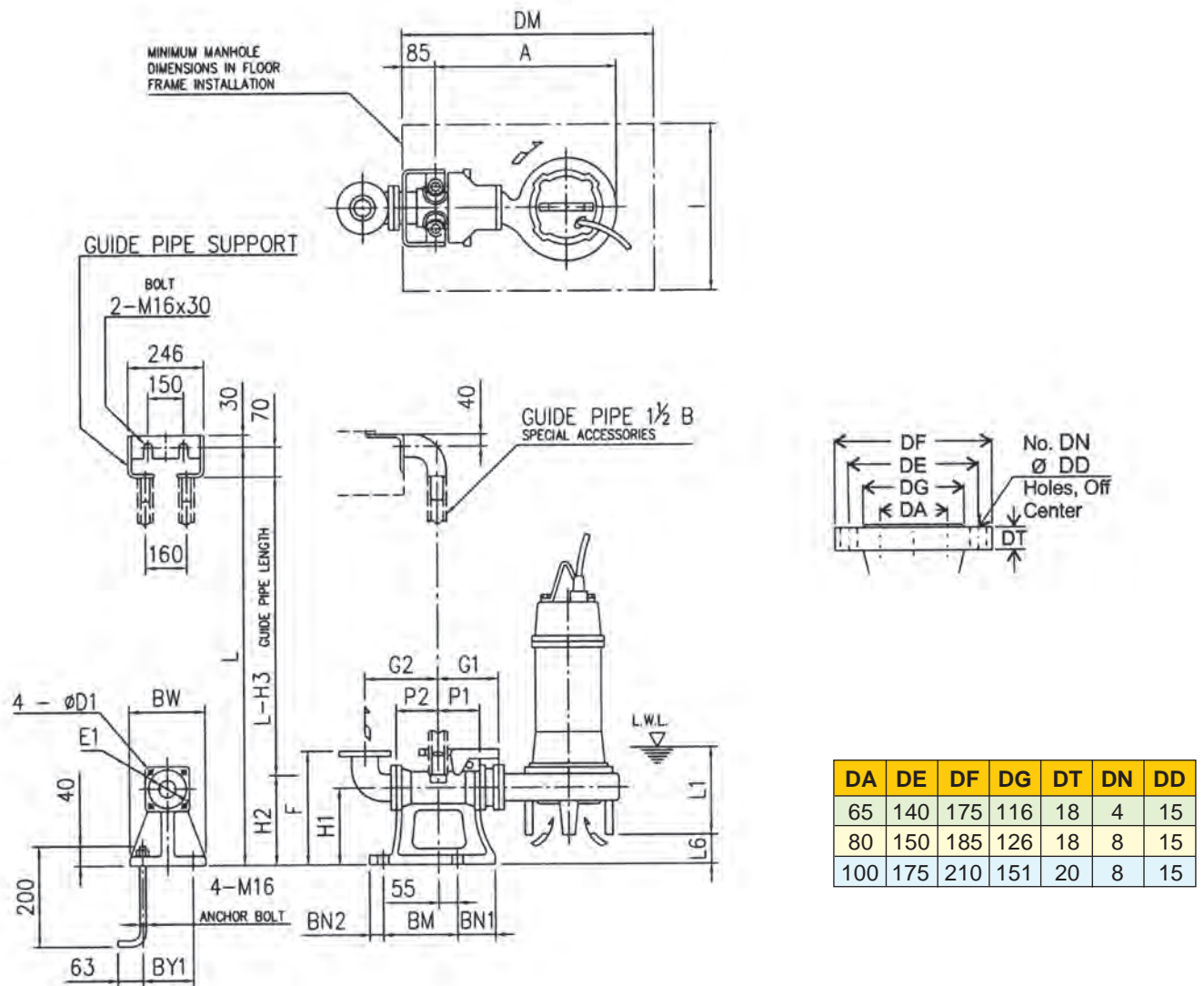

Size DA	Model	Output [kW]	A	P1	P2	G1	G2	F	H1	H2	H3	L1 (*)	L6	BN1	BN2	BM	BY1	BW	DM	I	D1	E1	QDC Model	QDC Weight [kg]
65	65 DLD 55.5A	5.5	605	105	125	185	190	315	210	240	310	260	100	100	40	195	160	210	950	800	12	140	LL65	41
	65 DLD 57.5A	7.5	672	105	125	185	190	315	210	240	310	260	100	100	40	195	160	210	950	800	12	140	LL65	41
	65 DL 511A	11	672	105	125	185	190	315	210	240	310	260	100	100	40	195	160	210	950	800	12	140	LL65	41
	65 DL 515A	15	728	105	125	185	190	315	210	240	310	280	100	100	40	195	160	210	1000	900	12	140	LL65	41
	65 DL 518A	18.5	728	105	125	185	190	315	210	240	310	280	100	100	40	195	160	210	1000	900	12	140	LL65	41
	65 DL 522A	22	728	105	125	185	190	315	210	240	310	280	100	100	40	195	160	210	1000	900	12	140	LL65	41
80	80 DLC 55.5	5.5	635	105	120	185	195	350	240	255	325	205	43	100	40	220	180	230	800	700	15	155	LL80	44
	80 DLC 57.5	7.5	665	105	120	185	195	350	240	255	325	205	45	100	40	220	180	230	800	700	15	155	LL80	44
	80 DLD 55.5A	5.5	605	105	125	185	190	320	210	240	310	260	100	100	40	195	160	210	950	800	12	140	LL65	41
	80 DLD 57.5A	7.5	672	105	125	185	190	320	210	240	310	260	100	100	40	195	160	210	950	800	12	140	LL65	41
	80 DL 511A	11	672	105	125	185	190	320	210	240	310	260	100	100	40	195	160	210	950	800	12	140	LL65	41
	80 DL 515A	15	728	105	125	185	190	320	210	240	310	280	100	100	40	195	160	210	1000	900	12	140	LL65	41
	80 DL 518A	18.5	728	105	125	185	190	320	210	240	310	280	100	100	40	195	160	210	1000	900	12	140	LL65	41
	80 DL 522A	22	728	105	125	185	190	320	210	240	310	280	100	100	40	195	160	210	1000	900	12	140	LL65	41
100	100 DL 53.7	3.7	589	105	105	185	210	365	240	265	335	185	115	100	40	220	180	230	800	700	19	175	LL100	46
	100 DLB 55.5	5.5	621	105	105	185	210	365	240	265	335	205	42	100	40	220	180	230	800	700	19	175	LL100	46
	100 DLC 55.5	5.5	635	105	120	185	225	365	240	255	325	205	43	100	40	220	180	230	800	700	15	155	LL80	44
	100 DLB 57.5	5.7	648	105	105	185	210	365	240	265	335	205	42	100	40	220	180	230	800	700	19	175	LL100	46
	100 DLC 57.5	7.5	665	105	120	185	225	365	240	255	325	205	45	100	40	220	180	230	800	700	15	155	LL80	44
	100 DL 511	11	676	105	105	185	210	365	240	265	335	205	42	100	40	220	180	230	1000	700	19	175	LL100	46
	100 DL 515	15	716	105	105	185	210	365	240	265	335	205	35	100	40	220	180	230	1000	700	19	175	LL100	46
	100 DL 518	18.5	716	105	105	185	210	365	240	265	335	205	35	100	40	220	180	230	1000	700	19	175	LL100	46

(*) - L.W.L (Low Water Level)

Units: mm unless otherwise specified

- Operation is limited to 10 minutes operation at L.W.L.
- Operation is limited to 30 minutes operation with water level below top of motor.

DIMENSION WITH QDC

Applicable Models - 150DL, 200DL

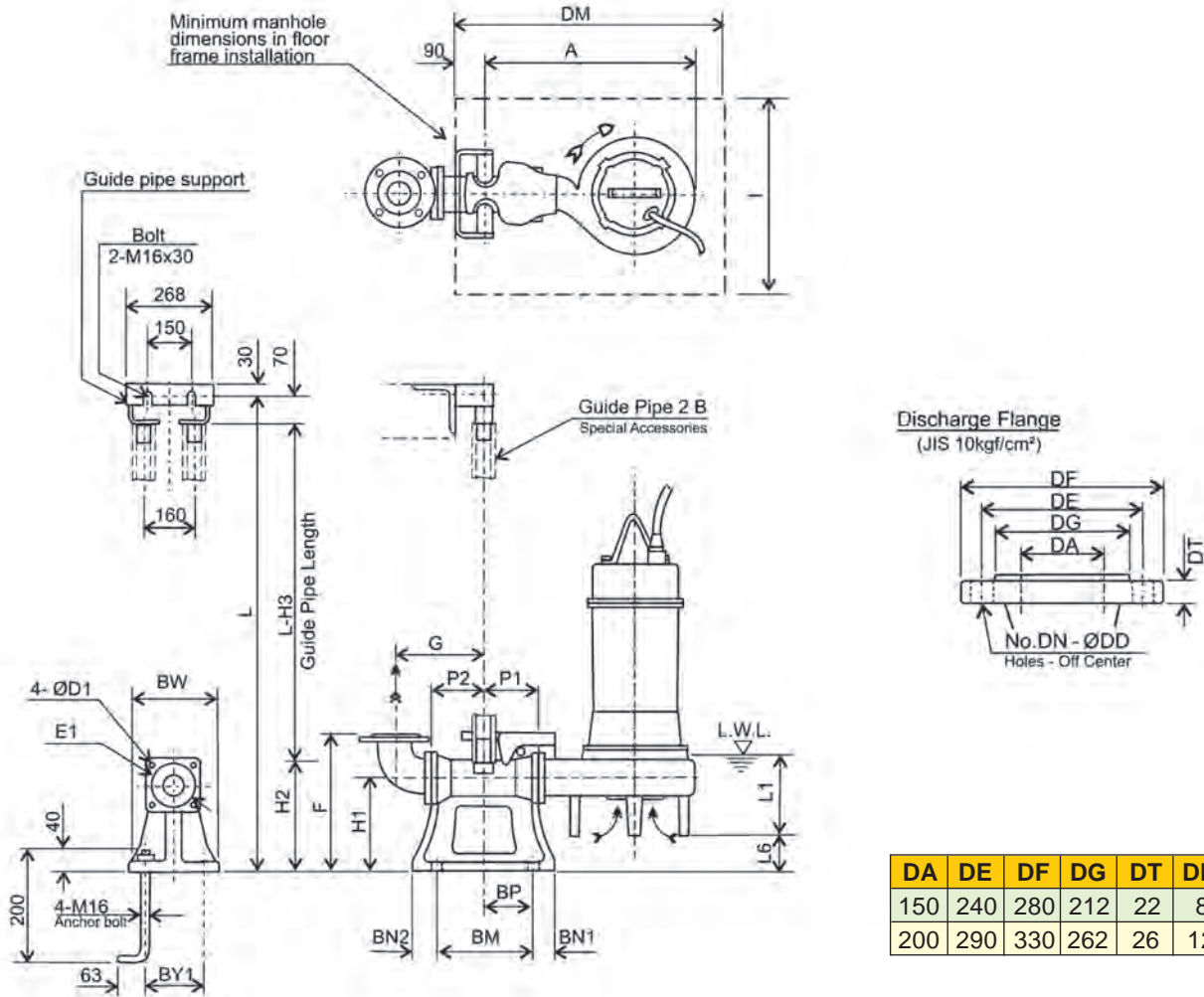

Size DA	Model	Output [kW]	A	P1	P2	G	F	H1	H2	H3	L1 (*)	L6	BN1	BN2	BM	BP	BY1	BW	DM	I	D1	E1	QDC Model	QDC Weight [kg]
150	150 DL 55.5	5.5	635	155	195	325	450	290	362	432	245	69	60	60	370	165	280	330	1000	700	16	210	LL125	65
	150 DL 57.5	7.5	665	155	195	325	450	290	362	432	245	73	60	60	370	165	280	330	1000	700	16	210	LL125	65
	150 DL 511	11	695	155	195	325	450	290	362	432	245	73	60	60	370	165	280	330	1000	700	16	210	LL125	65
	150 DL 515	15	695	155	195	325	450	290	362	432	245	73	60	60	370	165	280	330	1000	700	16	210	LL125	65
	150 DL 518	18.5	733	155	195	325	450	290	362	432	245	69	60	60	370	165	280	330	1000	700	16	210	LL125	65
	150 DL 522	22	733	155	195	325	450	290	362	432	245	69	60	60	370	165	280	330	1000	700	16	210	LL125	65
	150 DL 530	30	777	155	205	355	480	320	405	475	288	210	60	60	390	170	300	350	1100	800	16	250	LL150	80
	150 DL 537	37	777	155	205	355	480	320	405	475	296	210	60	60	390	170	300	350	1100	800	16	250	LL150	80
	150 DL 545	45	777	155	205	355	480	320	405	475	296	210	60	60	390	170	300	350	1100	800	16	250	LL150	80
200	200 DL 55.5	5.5	672	155	205	355	495	320	405	475	285	81	60	60	390	170	300	350	1100	800	16	250	LL150	80
	200 DL 57.5	7.5	703	155	205	355	495	320	405	475	285	85	60	60	390	170	300	350	1100	800	16	250	LL150	80
	200 DL 511	11	703	155	205	355	495	320	405	475	285	85	60	60	390	170	300	350	1100	800	16	250	LL150	80
	200 DL 515	15	736	155	205	355	495	320	405	475	285	84	60	60	390	170	300	350	1100	800	16	250	LL150	80
	200 DL 518	18.5	772	155	205	355	495	320	405	475	285	80	60	60	390	170	300	350	1100	800	16	250	LL150	80
	200 DL 522	22	772	155	205	355	495	320	405	475	285	80	60	60	390	170	300	350	1100	800	16	250	LL150	80
	200 DL 530	30	777	155	205	355	495	320	405	475	288	210	60	60	390	170	300	350	1100	800	16	250	LL150	80
	200 DL 537	37	777	155	205	355	495	320	405	475	296	210	60	60	390	170	300	350	1100	800	16	250	LL150	80
	200 DL 545	45	777	155	205	355	495	320	405	475	296	210	60	60	390	170	300	350	1100	800	16	250	LL150	80

(*) - L.W.L (Low Water Level)

- Operation is limited to 10 minutes operation at L.W.L.

- Operation is limited to 30 minutes operation with water level below top of motor.

Units: mm unless otherwise specified

DIMENSION WITH QDC

Applicable Models - 250DL, 300DL

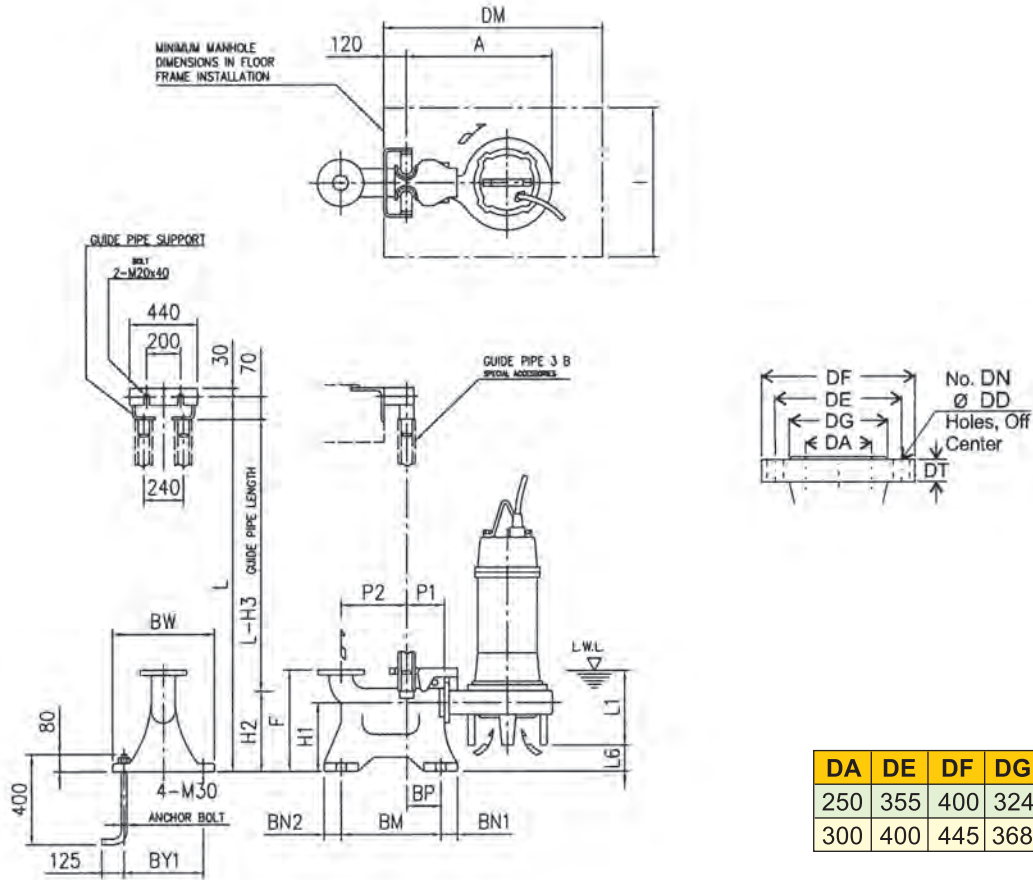

DA	DE	DF	DG	DT	DN	DD
250	355	400	324	30	12	25
300	400	445	368	32	16	25

Size DA	Model	Output [kW]	A	P1	P2	F	H1	H2	H3	L1 (*)	L6	BN1	BN2	BM	BP	BY1	BW	DM	I	QDC Model	QDC Weight [kg]
250	250 DL 57.5	7.5	834	195	435	700	350	440	510	400	58	70	70	650	215	500	560	1200	900	LL250	150
	250 DL 511	11	858	195	435	700	350	440	510	400	46	70	70	650	215	500	560	1200	900	LL250	150
	250 DL 515	15	872	195	435	700	350	440	510	400	34	70	70	650	215	500	560	1200	900	LL250	150
	250 DL 518	18.5	872	195	435	700	350	440	510	400	34	70	70	650	215	500	560	1200	900	LL250	150
	250 DL 522	22	872	195	435	700	350	440	510	400	34	70	70	650	215	500	560	1200	900	LL250	150
	250 DL 530	30	990	195	465	970	430	550	620	292	300	70	70	680	215	580	640	1300	900	LL300D	200
	250 DL 537	37	990	195	465	970	430	550	620	319	300	70	70	680	215	580	640	1300	900	LL300D	200
	250 DL 545	45	990	195	465	970	430	550	620	319	300	70	70	680	215	580	640	1300	900	LL300D	200
300	300 DL 511	11	917	195	465	800	430	550	620	450	109	70	70	680	215	580	640	1200	900	LL300	200
	300 DL 515	15	917	195	465	800	430	550	620	450	109	70	70	680	215	580	640	1200	900	LL300	200
	300 DL 518	18.5	952	195	465	800	430	550	620	450	112	70	70	680	215	580	640	1200	900	LL300	200
	300 DL 522	22	952	195	465	800	430	550	620	450	112	70	70	680	215	580	640	1200	900	LL300	200
	300 DL 530	30	990	195	465	800	430	550	620	292	300	70	70	680	215	580	640	1300	900	LL300D	200
	300 DL 537	37	990	195	465	800	430	550	620	319	300	70	70	680	215	580	640	1300	900	LL300D	200
	300 DL 545	45	990	195	465	800	430	550	620	319	300	70	70	680	215	580	640	1300	900	LL300D	200

(*) - L.W.L (Low Water Level)
 - Operation is limited to 10 minutes operation at L.W.L.
 - Operation is limited to 30 minutes operation with water level below top of motor.

Units: mm unless otherwise specified

* Dimensional details are provided for reference only.
 * All specifications are subject to change without prior notice.

EBARA Pumps Malaysia Sdn Bhd
 6, Jalan TP3, UEP Subang Jaya Industrial Park,
 47620 Subang Jaya, Selangor, Malaysia.
 Tel : 03-8023 6622 Fax : 03-8023 9355
 Email : sales.epm@ebar.com
 Website : www.ebara.com.my



Authorised dealer: